

Expressive Flexibility and Resilience among U.S. Military College Students: Evaluating the Enhancing and Suppressing of Emotions and Resilience

Vasiliki Georgoulas-Sherry¹ 

Abstract

Significant research has confirmed the necessity to better comprehend psychological constructs that are essential in predicting and influencing human performance, in particular, assessing expressive flexibility and resilience. However, limited research has investigated the relationships that exist between these two constructs that are critical protective factors in facilitating the mental health and the well-being of individuals. Through a number of structural equation modeling (SEM) techniques, the current endeavor evaluates this gap to assess the relationship between these two constructs. Utilizing a military student sample from a private U.S. military university ($N = 107$), participants completed the Resilience Scale for Adults (RSA) and the Flexible Regulation of Emotional Expression (FREE) scale. Correlations matrixes reported positive relationships between expressive flexibility and resilience. Confirmatory factor analyses (CFAs) revealed a bi-factor models of expressive flexibility and resilience. Additional CFAs revealed a two-factor model structure between expressive flexibility and resilience. Implications for future work are offered.

Keywords: Expressive flexibility, emotional expression, resilience, military, well-being

Numerous research endeavors have supported the necessity to better comprehend expressive flexibility (e.g., the enhancement and suppression of emotions) and resilience (e.g., appropriately adapt to significant stressor and bounce back to normal functioning), including assessing the relationship between these two constructs, as they continue to play a significant role in shaping, assessing, and predicting human performance (Rodin et al., 2017; Westphal, Seivery, & Bonanno, 2010; Zhu & Bonanno, 2017). Such research has shown that the ability to enhance and suppress emotions and be resilient, has been integral in predicting positive stress responses (Fossion, Leys, Kempnaers, Braun, Verbanck, & Linkowski, 2014), adaptability (Bartone, Kelly, & Matthews, 2013), physical and social functioning in aging individuals (Silverman, Molton,

Alschuler, Ede, & Jensen, 2015), reductions in “pain catastrophizing” (Ong, Zautra, & Reid, 2010), successful leadership and military performance (Maddi, Matthews, Kelly, Villarreal, & White, 2012), and neuro-immunological responses to stress (Sandvik, Hansen, Hystad, Johnsen, & Bartone, 2015).

Improved understanding of the relationship between these two constructs is imperative to comprehend and further assess, especially when confronted with adverse circumstances that are physically and cognitively taxing (Rodin et al., 2017). Now more than ever, as our Armed Forces and our civilians are subjected to such adversity, a focus must be placed in evaluating expressive flexibility and resilience as they are key protective factors in individual well-being; the value of comprehending these constructs are incalculable as

Corresponding Author: Vasiliki Georgoulas-Sherry, Teachers College, Columbia University, 525 West 120th St. New York, NY 10027

Email: vg2346@tc.columbia.edu

¹Teachers College, Columbia University, New York, NY, United States

these adverse contexts and situations can produce permanent physiological and psychological wounds (Chen, Chen, & Bonanno, 2018; Westphal et al., 2010).

Ozer, Best, Lipsey, & Weiss (2003) and Bonanno (2004) reported that a significant sample of the U.S. population, at some point in their lives, will be subject to at least one adversarial situation which can influence mental and cognitive health, including well-being. As most individuals will be exposed to some adversity or hardship, there is justified rationale to further understand expressive flexibility and resilience as these are necessary constructs that can help protect and shield individuals from the impact of adverse circumstances (Bonanno, 2004; Bonanno, Galea, Bucciarelli & Vlahov, 2007; Chen et al., 2018; Southwick, Bonanno, Masten, Panter-Brick, & Yehuda, 2014); more so, the ability to enhance and suppress emotions and be resilient also supports the need to maintain homeostasis through those adversative experiences, which encourages improved well-being, increased cognitive and mental health, and improved psychological adjustment (Rodin et al., 2017). Being able to be resilient and enhance and suppress emotions is important in overcoming such stressors that are unavoidable in life. Research such as this one, is vital to the comprehension of these constructs.

Furthermore, research has assessed the role that expressive flexibility and resilience has on overall well-being, effective adaptation, and consequently, long-term adjustment (Burton & Bonanno, 2015; Bonanno et al., 2007; Westphal et al., 2010). Overall well-being (e.g., healthy welfare, positive contentment) is dependent on the ability to cope with and bounce back from crisis to promote and protect the self; for example, in adverse environments people must possess the ability for personal development and growth accompanied with feelings of purposefulness (Bonanno et al., 2007; Sandvik et al., 2015). Effective adaptation (e.g., preserving homeostasis, successful acclimatization) is contingent on the capability to enhance and suppress emotions in a flexible amendable manner; in adverse environments specifically, individuals must be able to respond to, adjust, and acclimate effectively (Rodin et al., 2017; Zhu & Bonanno, 2017). Furthermore, Bonanno et al. (2007) has shown that expressive flexibility predicts long-term adjustment. For example, in a combat environment, a soldier must be able to interact and normalize internal states through confidence (Bartone et al., 20013), create, expand, and preserve social relationships (Ong et al., 2010), handle

successful conflict mediation (Chen et al., 2018; Rodin et al., 2017; Southwick et al., 2014), and promote the ability to bounce back and recover into homeostasis (Southwick et al., 2014).

While several studies have investigated expressive flexibility and resilience, limited research endeavors have assessed the relationship that exists between these two psychological constructs. Furthermore, the current interest to better understand the psychological constructs that have been integral and valuable during adverse situations and contexts, has generated an increased demand to understand the interplays between expressive flexibility and resilience. Furthermore, research endeavors such as this one can help with operationalization of these constructs that play a significant role in shaping, assessing, and predicting human performance and in fostering appropriate and healthy cognitive and mental wellness (Rodin et al., 2017).

Resilience

For several decades, social scientists have considered the definition of resilience to be problematic and complex due to the numerous attempts to operationalize this psychological construct. Research studies has investigated resilience in various environments and contexts, which would add to the complication of its operationalization (Bonanno et al., 2007; Fossion et al., 2014; Southwick et al., 2014). While the operationalization of resilience continues to be debate, there are several elements that are consistent. For example, resilient individuals have the tendency to “bounce back” from a negative experience with “competent functioning.” Resilient individuals are not without negative thoughts and emotions. Instead, they are more likely to possess coping skills and mechanisms to navigate through trauma efficiently and effectively, and successfully balance positive with negative feelings. Individuals who are resilient are able to encounter temporary disruptions during a state of homeostasis, but are more likely to show a “stable trajectory of healthy functioning” across a period of time and possess a more positive outlook (Bonanno, Papa, & O’Neill, 2001; Friborg, Barlaug, Martinussen, Rosenvinge, & Hjemdal, 2005). Someone who is resilient can survive intense levels of trauma and adversity, while at the same time, protecting their mental health and psychological stability (Sandvik et al., 2015). Through resilience, an individual is able to continue and maintain homeostasis during challenging circumstances (Southwick et al., 2014).

Expressive Flexibility

Expressive flexibility is the ability to enhance and suppress emotions. The ability to enhance emotions is the ability to demonstrate improved and heightened potential emotional expression; the ability to suppress emotions is characterized as the capacity to demonstrate reduced and repressed potential emotional expression. In both instances, both in expressive enhancement and suppression abilities, context and situation are necessary. Expressive flexibility is as an essential element in successful psychological adjustment and health (Aldao, Sheppes, & Gross, 2015; Burton & Bonanno, 2015; Chen et al., 2018; Westphal et al., 2010). Specifically, the capability to be expressively flexible, both through expressive enhancement and in expressive suppression, is integral in the successful adaptation and acclimation to adverse situations and contexts. For example, research has shown that greater levels of expressive flexibility has shown to function as a barrier against trauma and stressors, (Rodin et al., 2017; Westphal et al., 2010) and support improved psychopathology (Bonanno et al., 2007; Rodin et al., 2017), mental health (Aldao et al., 2015), psychological adjustment (Aldao et al., 2015; Burton & Bonanno, 2015; Westphal et al., 2010), and well-being (Gross & John, 2003; Webb, Miles, & Sheeran, 2012). Furthermore, the ability to enhance and suppress emotions links to significant social and clinical effects following exposure to adverse circumstances (Westphal et al., 2010).

A lack of regulation in expressive flexibility (i.e., inability of successful enhancement and suppression of emotions) has been linked to prevalent and enduring cognitive, emotional, health, and social costs (Bonanno et al., 2007; Burton & Bonanno, 2015; Gross & John, 2003; Westphal et al., 2010). For example, individuals who lack expressive flexibility are more likely to suffer from negative emotions (Zhu & Bonanno, 2017), declined well-being (Aldao et al., 2015; Chen et al., 2018; Webb et al., 2012), and diminished rapport and social interaction (Gross & John, 2003). On the contrary, individuals who are high on expressive enhancement are more likely to facilitate and sustain positive and healthy social networks (Gross & John, 2003), possess successful long-term functioning (Chen et al., 2018), and show diminished negative affect in adverse contexts (Rodin et al., 2017; Webb et al., 2012).

Present Study

Expressive flexibility and resilience have shown to be integral in prevailing over failures, challenges, and hardships; these psychological constructs are critical

protective factors in facilitating mental health and the well-being of individuals. However, to the author's knowledge, there are no studies that have assessed the relationships between these constructs. For that reason, the key focus of the current study is to explore the interrelated, but discrete psychological constructs. Through the use of SEM methods such as correlation matrixes and confirmatory factor analyses (CFA), this project endeavors to evaluate multiple models that best assess the relationship and structure between expressive flexibility and resilience. These aims focus on the theoretical frameworks in conveying empirical indicators across these constructs. We endeavor to answer:

1. What is the empirical relationship between expressive flexibility and resilience, and more specifically, what is the factor structures of these two psychological constructs?
2. How are then, expressive flexibility and resilience linked to one another, and more specifically, are there significant covariances between these constructs?

Method

Participants

Participants recruited from this study came from a private U.S. military university that houses all military branches. The sample of 107 participants for this study, who identified as either male (66%) or female (34%), ranging from 18 to 22, was comparable to the total sample size. Over a third of the participants were either 19 years old (38%) or 18 years old (34%); this was consistent to participants' grade level with 40% being freshmen and 34% being sophomores. The rest were either juniors or seniors (26%). As members of the Corps of Cadets, half of the participants (54.2%) reported that they were a leader within their cadet group.

Measures

Resilience Scale for Adults (RSA) (Friborg et al., 2005). The first (self-report) scale administered was the 32-item RSA scale. This scale measures resilience through evaluating interpersonal and intrapersonal protective factors associated with this construct. The RSA has two different sections. The first section of the RSA includes 25 items on a 7-point Likert-type scale; these items are rated on a 7-point scale from 1 (strongly disagree) to 7 (strongly agree), with higher scores indicating a higher degree of resilience. The second section includes two questions on mental and physical health, while the third section includes similar health questions with a "yes" or "no" response. Items include

“I am friends with myself” and “I have self-discipline.” The RSA has revealed high internal consistency reliability ($\alpha = .72$ to $.94$) (Friborg et al., 2005).

The Flexible Regulation of Emotional Expression (FREE) Scale (Burton & Bonanno, 2015). The second (self-report) scale administered was the 16-item FREE scale. This scale measures a person’s ability to enhance and suppress displayed emotion across an array of hypothetical contexts. The FREE scale has 16 scenarios, and those scenarios were categorized into four types of sections: (a) enhancing positive emotion, (b) enhancing negative emotion, (c) suppressing positive emotion, and (d) suppressing negative emotion. Each item asks the participants to indicate how well they are able to express or conceal their feelings respective to each scenario on a 6-point scale, ranging from 1 (not at all) to 6 (very much). Items include “The following scenarios involve POSITIVE emotion. For each scenario indicate how well would you be able to be even MORE EXPRESSIVE than usual of how you were feeling: A friend wins an award for a sport that doesn’t interest you” and “The following scenarios involve NEGATIVE emotion. For each scenario indicate how well would you be able to CONCEAL how you were feeling: You are at a social event and the person you’re talking to frequently spits while they speak.” Results from Burton and Bonanno (2015) showed frequency of expressive suppression ($\alpha = .79$) and cognitive reappraisal ($\alpha = .87$).

Procedure

Teacher’s College, Columbia University’s Institutional Review Board (IRB) approved this study. Recruitment occurred via word-of-mouth (i.e., professors provided extra credit for study participation). Participants did not receive payment for participation; however, they were eligible for extra credit in their psychology course. This study did not purposefully exclude anyone by gender, class, race, or age. Using a cross-sectional design,

participants received a Qualtrics link to complete the two scales, the RSA and the FREE scale.

Results

Data Analysis

G*Power 3.1.9.2 provided a sample size of 108 participants for medium-sized effects (Cohen’s $f = .32$) with acceptable statistical power (Faul, Erdfelder, Buchner, & Lang, 2009). All participants completed the two scales: the RSA and the FREE scale. Overall, participants self-reported as moderately resilient ($M = 5.54$, $SD = .93$) and moderately flexible in regulation of emotional expression (e.g., expressive flexibility) ($M = 11.99$, $SD = 1.77$). Females were significantly less likely to be resilient ($M = 5.29$, $SD = 1.13$) than males ($M = 5.67$, $SD = 0.79$) ($t(105) = 2.01$, $p = .047$). However, there were no significant differences between gender and expressive flexibility ($t(105) = -0.45$, $p = .66$, *NS*). Additionally, there were no significant differences in age and expressive flexibility ($F(4, 102) = 1.07$, $p = .37$, *NS*) or resilience ($F(4, 102) = 2.10$, $p = .08$, *NS*).

To examine the constructs of expressive flexibility and resilience, CFA models were utilized to investigate the single-, bi-, and multiple-factor model (i.e., hierarchical model) structures for best fit; this study endeavored to examine the factor structures and the associations between expressive flexibility and resilience (see Table 1). Through SPSS’ Analysis of Moment Structures (AMOS), CFA models tested the structures that best describe the constructs. Additionally, to describe the relationships amongst these constructs, CFA models were used. Pearson r correlations computed the direction and strength between the constructs. Assumptions were satisfactory; the skewness ranged from -1.72 to 1.36 and kurtosis ranged from $-.42$ to 1.47 , and the assumption of multivariate normality was not violated. Findings did not present multivariate outliers (Finney & DiStefano, 2006).

Table 1. Dimensions of the expressive flexibility and resilience

Expressive Flexibility	FLE	Positive Expressive	EXP+
		Negative Expressive	EXP-
		Positive Conceal	CON+
		Negative Conceal	CON-
Resilience	RES	Perseverance	PERS
		Meaning of Life	MEAN
		Serenity	SERE
		Self-Reliance and Self-Confidence	SELF

Table 2. Model fit statistics and indexes associated with the models

	χ^2	<i>df</i>	TLI	RMSEA	CFI
Expressive Flexibility					
Model 1 (unidimensional model)	508.57	104	.38	.19	.46
Model 2 (four-factor model)	342.63	98	.60	.15	.67
Model 3 (bi-factor model)	176.70	98	.84	.09	.79
Resilience					
Model 1 (unidimensional model)	1356.64	275	.51	.19	.55
Model 2 (four-factor model)	1118.40	224	.54	.19	.59
Model 3 (bi-factor model)	893.70	224	.70	.17	.76
Expressive Flexibility & Resilience					
Model 4	49.16	19	.92	.12	.94

Note. CFI = Comparative Fit Index; TLI = Tucker-Lewis Index; RMSEA = Root Mean Square Error of Approximation; all models were statistically significant ($p < .05$)

For each construct, a CFA model via maximum likelihood (ML) estimation was implemented: (1) Model 1 was a unidimensional model of each construct wherein all the items loaded onto a single latent factor, (2) Model 2 was a multi-factor model (four-factor model for expressive flexibility or four-factor model for resilience) with no hierarchical structure, and (3) Model 3 was a bi-factor model of each construct. Traditional model-fit indices were employed: (1) Comparative Fit Index (CFI), (2) Tucker-Lewis Index (TLI), and (3) Root Mean Square of Approximation (RMSEA) (see Table 2).

CFA Expressive Flexibility Models

Model 1 examined a unidimensional model of expressive flexibility, however, results revealed poor fit indices. All sixteen items loaded significantly (at the $p < .001$ level) on expressive flexibility with a factor loading ranging from .01 to .68. Model 2 investigated a four-factor model of expressive flexibility (which consisted of positive expressive, negative expressive, positive conceal, and negative conceal); this

measurement model produced poor fit indices. In this four-factor model, all items significantly loaded on positive expressive, negative expressive, positive conceal, and negative conceal with a factor loading ranging from .01 to .68. Model 3 tested a bi-factor model of expressive flexibility, which consisted of expressive flexibility as the higher-order factor and positive expressive, negative expressive, positive conceal, and negative conceal as the first order factors. Like the following models, Model 3 generated poor fit indices even though TLI was .84. The bi-factor model of expressive flexibility was the better of three models due to proximity in TLI and RMSEA benchmarks for good fit (see Table 2).

Overall expressive flexibility correlated significantly with positive expressive ($r = .669, p < .001$), negative expressive ($r = .670, p < .001$), positive conceal ($r = .755, p < .001$), negative conceal ($r = .832, p < .001$), resilience ($r = .369, p < .001$), perseverance ($r = .328, p = .001$), meaning of life ($r = .403, p = .001$), serenity ($r = .270, p = .005$), and self-reliance and self-confidence ($r = .408, p < .001$) (see Table 3).

Table 3. Covariance matrix of the psychological constructs

	Expressive Flexibility					Resilience				
	FLE	EXP+	EXP-	CON+	CON-	RES	PERS	MEAN	SERE	SELF
FLE	1									
EXP+	0.67**	1								
EXP-	0.67**	0.51**	1							
CON+	0.76**	0.26**	0.19	1						
CON-	0.83**	0.34**	0.41**	0.51**	1					
RES	0.37**	0.26**	0.21*	0.31**	0.30**	1				
PERS	0.33**	0.24*	0.14	0.32**	0.25**	0.93**	1			
MEAN	0.40**	0.23*	0.23*	0.36**	0.35**	0.89**	0.74**	1		
SERE	0.27**	0.20*	0.19*	0.18	0.23*	0.91**	0.80**	0.75**	1	
SELF	0.41**	0.32**	0.27**	0.29**	0.33**	0.95**	0.83**	0.83**	0.86**	1

** = Correlation is significant at the 0.01 level (2-tailed)

* = Correlation is significant at the 0.05 level (2-tailed)

CFA Resilience Models

Three models evaluated the construct of resilience. The first model, Model 1, assessed a unidimensional model of resilience. Findings showed overall poor fit indices. All items ($N = 25$) significantly loaded on resilience with a range of factor loadings from .06 to .81. A four-factor model of resilience, Model 2 of resilience, which comprised of perseverance (i.e., item 7, 12, 15, 16, 17, 21, 22), meaning of life (i.e., item 3, 5, 8, 13, 14, 19), serenity (i.e., item 6, 9, 10, 11, 20), and self-reliance and self-confidence (i.e., item 1, 2, 4, 18, 23) was reviewed; this measurement model produced poor fit indices. All items significantly loaded on the four factors with a factor loading ranging from .06 to .82. Model 3 tested a bi-factor model of resilience, which consisted of resilience as the higher-order factor and meaning of life, serenity, perseverance, and self-reliance and self-confidence as the first order factors. Like the following models, Model 3 generated poor fit indices. Model 3 was the better of the three models due to proximity in TLI benchmark for good fit (see Table 2). Overall resilience highly correlated significantly with perseverance ($r = .929, p < .001$), meaning of life ($r = .886, p = .001$), serenity ($r = .910, p = .005$), self-reliance and self-confidence ($r = .948, p < .001$), expressive flexibility ($r = .369, p < .001$), positive expressive ($r = .262, p = .007$), negative expressive ($r = .211, p = .029$), positive conceal ($r = .309, p = .001$), and negative conceal ($r = .301, p = .002$) (see Table 3).

CFA Model of Expressive Flexibility and Resilience

A CFA model was employed to determine model structures that can sufficiently describe the best fit relationship between the constructs of expressive flexibility and resilience. Model 4 examined a two-factor model which consisted of two latent factors: (1) expressive flexibility and (2) resilience. The latent factor of expressive flexibility comprised of four indicators (positive expressive, negative expressive, positive conceal, and negative conceal). The latent factor of resilience comprised of four indicators (perseverance, meaning of life, serenity, and self-reliance and self-confidence). Model 4 generated appropriate fit indices (see Table 2). Model 4 was the better of the three models (see Figure 1).

Additionally, in Model 4, the factor loadings were statistically significant (at the $p < .001$ level) and in the anticipated direction, which suggests the measurement model was appropriate (Griffin, Botvin, Scheier, Epstein, & Doyle, 2002). The latent factor of expressive

flexibility had factor loadings ranging from .48 to .83. The latent factor of resilience had factor loadings ranging from .86 to .96. Additionally, expressive flexibility accounted for 70% of the negative conceal indicator. Also, resilience accounted for 92% of the self-reliance and self-confidence indicator. Figure 1 depicts the further correlations between the latent factors of expressive flexibility and resilience and each item's residual variance terms.

Discussion

The psychological constructs of expressive flexibility and resilience are critical protective factors in facilitating the mental health and the well-being of individuals. Prior research has assessed relationship between resilience and expressive flexibility, supporting the ability to adopt stable and low levels of anxiety and concern, which, in return, enhances well-being (Burton & Bonanno, 2015; Chen et al., 2018; Westphal et al., 2010). Through the use of a number of SEM methods to account for the factor structures and the associations between expressive flexibility and resilience, the main goal of the current study was to examine the distinct, but related psychological constructs. Several CFA models assessed the model structures that can appropriately examine the best fit. Results revealed that a bi-factor model best fit expressive flexibility and resilience. Further CFAs were employed to assess the best model structure that can examine the adequate relationship between these constructs.

The bi-factor model of expressive flexibility and resilience, as Griffin et al. (2002) explain, assess the direct effects within this model, supporting the notion that each observed variable (i.e., the items on each scale) were able to contribute variance to the constructs of expressive flexibility and resilience, respectively. Specifically, the observed variables, not the subfacets characterized expressive flexibility and resilience as seen in the bi-factor model structure. While the hypotheses suggested that expressive flexibility and resilience would be best described through a four-factor model structure, direct effects within each item of the scales contributed to these constructs. For example, the bi-factor model of resilience generated better model indexes than the four-factor model structure – the items loaded on to resilience better than meaning of life, serenity, perseverance, and self-reliance and self-confidence. These results were comparable for the construct of expressive flexibility.

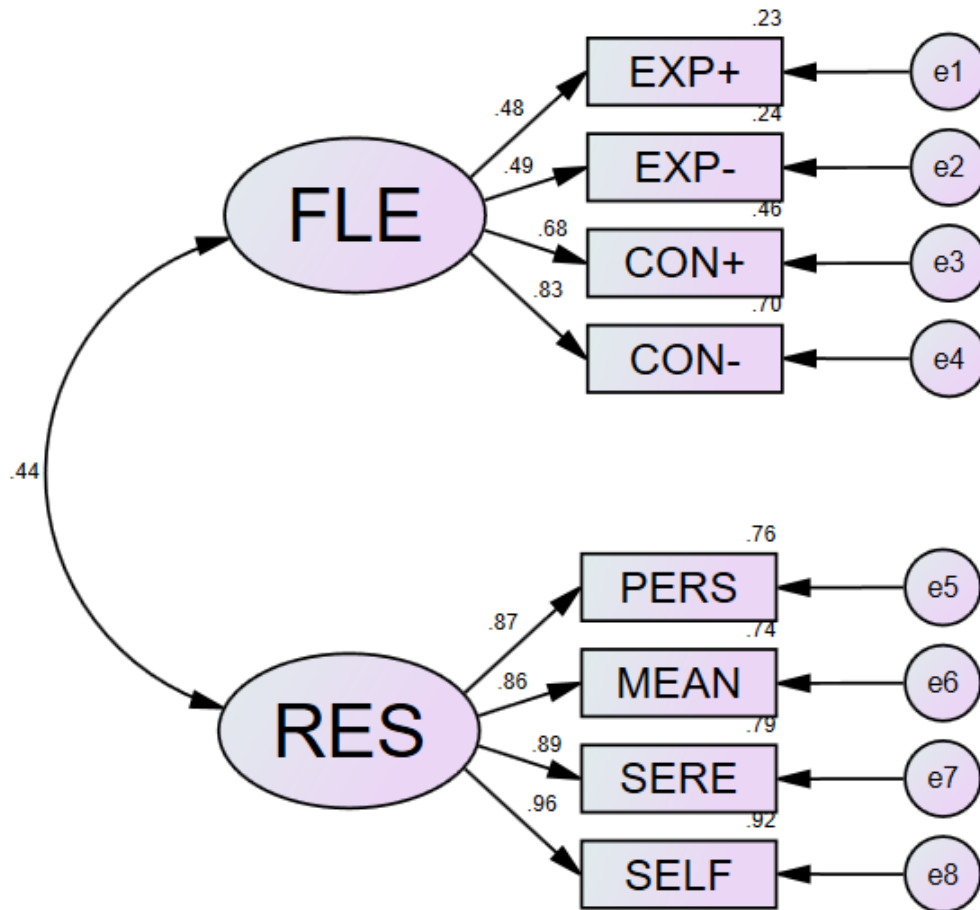

Figure 1. Confirmatory factor analysis of expressive flexibility and resilience

Figure 1 represents the conceptual model displaying the relationships between expressive flexibility and resilience as related to the two assessment instruments, the FREE and RSA. Standard regression coefficients were compared across the assessments. The correlation coefficients between expressive flexibility and resilience exhibited via double headed arrow

Findings from this study supported Chen et al. (2018)'s results correlating resilience and expressive flexibility positively ($r = .33, p < .01$); interestingly though, in the same study, Chen et al. (2018) assessed a four-factor and a hierarchical model of expressive flexibility, both with adequate fit indices. Additionally, Burton and Bonanno (2015) conducted several CFAs to support that the FREE Scale included four first-order factors (i.e., positive expressive, negative expressive, positive conceal, negative conceal) to two higher order factors (i.e., enhance and suppress emotions); additionally, while Burton and Bonanno (2015)'s study did not evaluate resilience, like this research, researchers did reveal a positive relationship between suppression of emotions and ego resilience ($r = .32, p < .01$). However, it is important to note, that ego resilience is distinct from resilience, in that, there is a link with ego control, which focuses on the capability to control aggression and anger. CFAs revealed a two-factor model structure between the two constructs. These findings suggest that

expressive flexibility and resilience, while related, are distinguishable from one another. Factor loadings were substantial; the four subfacets of expressive flexibility (i.e., positive expressive, negative expressive, positive conceal, and negative conceal) loaded on the expressive flexibility value and the four subfacets of resilience (i.e., meaning of life, serenity, perseverance, and self-reliance and self-confidence) loaded on the resilience value. Prior to this research, these structures were not wholly empirically examined, and several implications can be derived from this study. Notably, the two-factor model structure endorsed the essential distinction of the two parallel but independent constructs. Unlike this study, Westphal et al. (2010) reported that suppression of emotions (i.e., one of the two higher order factors as presented in Burton and Bonanno (2015) predicted resilience, not enhancement of emotions. Despite theoretical assumptions and considerations, empirical support like this study and Westphal et al. (2010) are

critical to examine the relationships between expressive flexibility and resilience.

As displayed in Model 4, expressive flexibility and resilience, and their respective subfacets, were theoretically associated, closely related with one another. Despite the theoretical parallels found throughout these two constructs and their subfacets, none described the constructs of expressive flexibility or resilience. While resilience has been described as an “umbrella term” as it incorporates an array of subfacets, these present outcomes reveal the independent capacity of these two constructs, not potential secondary associations. While results revealed several moderate and strong associations between these two constructs, there were some significant findings to describe. Findings of this research endeavor show that expressive flexibility was correlated to resilience and subscales and vice versa. It is notable to state that perseverance or positive conceal was not correlated with negative expressive; furthermore, serenity was not associated with positive conceal. As results showed, the bi-factor model was the best fit model for expressive flexibility. In a militant context, the facilitating and predicting of successful mental health and the well-being of individuals is critical (Maddi et al., 2012; Sandvik et al., 2015). Additionally, as expressive flexibility has shown to predict an increase mental adjustment and a decrease in psychopathological symptomology (Bonanno et al., 2007; Chen et al., 2018; Southwick et al., 2014), it would be crucial to comprehend expressive flexibility and resilience that play a vital role in shaping and impacting human performance. For instance, soldiers must be able to appropriately enhance and suppress emotions (i.e., be expressive flexible) and bounce back and cope after hardship (i.e., be resilient). While this endeavor employed a military sample, this study can generalize to non-military populations.

Limitations

A number of limitations influenced the results of this study. First, this study utilized a military college population, and the results might not be generalizable or replicable beyond the military sample. Since participants were from a private US Military university, this sample did not have a broad range of expressive flexibility or resilience levels. Due to the lack of variability and the stronger presentation of expressive flexibility and resilience, this limitation could have lowered correlations and impacted regressions. As most US Military universities’ curriculums demand levels of expressive flexibility and resilience unexpected in other

institutions, further analyses with military non-cadet samples needs evaluation. While this study employed a military sample, a study with soldiers might be of interest. Analyses with military sample, and even more noteworthy, a combat exposed military sample. Additionally, a larger sample can benefit this study.

Second, a limitation includes the recruitment process since participants volunteered to complete this study to gain extra credit in their respective psychology courses. While recruiting participants from their psychology courses and providing them with extra credit to participate is a common method of recruitment in the social sciences field, there are risks in interpreting studies conducted in this context. Furthermore, each scale that participants completed was self-report; while self-reports are also a common methodology in many behavioral science disciplines, there are many risks to this methodology. As we utilized a military population, many cadets might have felt that they should report as more resilient or more likely to expressively flexible as they are starting their military life. Participants, for example, might not have reported truthfully to their expressive flexibility and resilience because of their role in the military. Additionally, this study used a small military college sample, and the results might not be generalizable or replicable. Further endeavors using a military sample (including active or veteran populations) would be of interest, including a larger sample.

Third, even though this research revealed significant findings, results did exhibit low levels of reliability, which could constrain the ability to apply this study’s conclusions. For example, these findings might not be reproducible or consistent under similar contexts. This limitation though, is present in previous work that has measured the theoretical structures and relationships of psychological constructs; decreased levels of reliability could imply that items were chosen to suggest the theoretical structure within the constructs instead of benefiting reliability. Notwithstanding this limitation, this research does enhance the current literature. Further work should continue to assess the consistency of results across items within such constructs, and the extent to which these measures are distinct from one another.

Lastly, this study could have benefitted from non-correlational methodology, as this focused on the theoretical structure of expressive flexibility and resilience and the relationship between these two constructs. While the two constructs were correlated to

each other, as shown in this endeavor, it would be noteworthy to evaluate how expressive flexibility and resilience are associated once these constructs are isolated and manipulated; different methodologies might generate different and perhaps, more meaningful findings that cannot be replicated or produced in correlational research. For example, resilience has been grounded on a person's emotional and mental capacity to bounce back from a trauma or crisis to a state of homeostasis. This study's methodology did not include placing an individual in a state of concern, crisis, or trauma, that is necessary to promote and encourage the capacity of resilience that individuals have, instead of the self-reported resilience. For example, Bonanno et al. (2007) were able to achieve significant findings on self-report resilience but their study included the administering of a phone survey to New York City residents following the events of September 11, 2001, not completing a survey for class credit with no exposure to crisis or trauma.

Implications and General Conclusion

The need to better understand the impact of expressive flexibility and resilience are incalculable as these two constructs are essential in influencing positive human performance, in promoting mentally healthy individuals, and in fostering protective mechanisms that shield individuals from adverse environments (Fossion et al., 2014; Maddi et al., 2012; Ong et al., 2010). Additionally, previous research has shown that expressive flexibility has predicted decreased psychological distress over a period and increased success in adapting to coping strategies (Bonanno et al., 2007; Chen et al., 2018); furthermore, research have shown that resilience is positively correlated with satisfaction with life, flourishing, and affect balance, and fully mediated the relationships amongst satisfaction with life, flourishing, and fear of happiness (Yildirim, 2018), promotes thriving following adverse events (Bonanno, 2004), and predicted flourishing and subjective well-being and fully mediated the relationships amongst flourishing, eternity of happiness, and subjective well-being (Yildirim & Belen, 2019). As these psychological constructs are integral factors in promoting stable mentally healthy individuals, in shaping human performance, in supporting successful adaptation to adversity, and in producing several protective mechanisms that shield individuals from stressful and adverse environments and situations, studies like these necessary (Rodin et al., 2017). The results showed that the two-factor model

structure for expressive flexibility and resilience supports the necessity to differentiate these two constructs from one another; further results show bi-factor models of expressive flexibility and resilience. These findings demonstrate the need of recommending against synonymously using these constructs as they are theoretically distinct from each other. Employing these terms reciprocally can yield misrepresentation and misleading and false work. Instead, this endeavor reveals the risk in applying these constructs in a similar fashion as they are unique and ought to continue as such.

Through SEM methods, this project evaluated multiple models that best assesses the relationship and structure between expressive flexibility and resilience. By better understanding the theoretical framework and empirical relationship between these constructs, researchers are more likely to better recognize how to decrease the possible vulnerability to further stressors or measure the supplementary impact on individual mental well-being. The more we learn about expressive flexibility and resilience, the more likely we are to incorporate salient concepts of expressive flexibility and resilience into relevant contextual environments for research in the fields of mental health, medicine, and science. Incorporating these concepts can facilitate a significant and necessary approach to thinking about adversity and challenge. According to Southwick et al. (2014), instead of focusing efforts and energy to the continued negative outcomes and impacts of adversity and trauma, a need to focus on the positive consequences that emerge from such crisis are as important, if not, more integral, to investigate and further examine; this can also be said about the construct of expressive flexibility. This potential paradigm shift could help move the mental health, medicine and science fields away from the typical "purely deficit-based model," to instead, models that focus on individualized strengths and positive human functioning (like expressive flexibility and resilience), which centers on the prevention and deterrence of dysfunction, and the facilitating of strengths and positive constructs in understanding and attending to psychopathology (Ozer et al., 2003; Southwick et al., 2014). Such research could also help better understand the effects of the psychological construct of expressive flexibility and resilience and its influence on individual mental health and well-being.

As this research study supported the need to better comprehend expressive flexibility and resilience and its

distinctions and similarities, these results can be significant in creating and designing the framework for training and scales; this project can play a vital role towards the development of such training and scales in order to facilitate the framework for better training and scales that focus on these constructs. While there are a small number of validated scales, it might be crucial to reevaluate these assessments in efforts to ensure that each psychological construct appropriately measures the intended constructs. This research study can also be vital in the facilitation and construction of various programs and trainings, and in developing and promoting the advancement of these interventions. If we can better distinguish these constructs, more effective programs, trainings, and interventions can support better mental health and well-being outcomes. This can aid in reducing possible deficiencies and preventing potential negative outcomes. Further studies can help better understand such psychological constructs.

The completion of this current study provides evidence of how expressive flexibility and resilience, two integral constructs in promoting and facilitating successful adaptation to homeostasis after exposure to adversity, relate to one another theoretically and structurally. As such, this study aimed to investigate the relationships that exist between these two constructs that are critical protective factors in facilitating mental health and the well-being of individuals through employing a number of SEM techniques to assess these relationships and the theoretical frameworks surrounding expressive flexibility and resilience.

Compliance with Ethical Standards

Ethical Approval

All procedures performed in studies involving human participants were in accordance with the ethical standards of the institutional and/or national research committee and with the 1964 Helsinki declaration and its later amendments or comparable ethical standards. Teacher's College, Columbia University's Institutional Review Board (IRB) also approved this study

Declaration of Conflicting Interests

The authors declared no potential conflicts of interest with respect to the research, authorship, and/or publication of this article.

Funding

The author(s) received no financial support for the research, authorship, and/or publication of this article.

ORCID

Vasiliki Georgoulas-Sherry  <https://orcid.org/0000-0003-2009-4959>

Received: June 26, 2020

Accepted: August 7, 2020

Published Online: August 20, 2020

References

- Aldao, A., Sheppes, G., & Gross, J. J. (2015). Emotion regulation flexibility. *Cognitive Therapy and Research*, 39(3), 263-278. <https://doi.org/10.1007/s10608-014-9662-4>
- Bartone, P. T., Kelly, D. R., & Matthews, M. D. (2013). Psychological hardiness predicts adaptability in military leaders: A prospective study. *International Journal of Selection and Assessment*, 21(2), 200-210. <https://doi.org/10.1111/ijsa.12029>
- Bonanno, G. A. (2004). Loss, trauma, and human resilience: Have we underestimated the human capacity to thrive after extremely aversive events? *American Psychologist*, 59(1), 20-28. <https://doi.org/10.1037/0003-066X.59.1.20>
- Bonanno, G. A., Galea, S., Bucciarelli, A., & Vlahov, D. (2007). What predicts psychological resilience after disaster? The role of demographics, resources, and life stress. *Journal of Consulting and Clinical Psychology*, 75(5), 671-682. <https://doi.org/10.1037/0022-006X.75.5.671>
- Bonanno, G. A., Papa, A., & O'Neill, K. (2001). Loss and human resilience. *Applied and Preventive Psychology*, 10(3), 193-206. [https://doi.org/10.1016/S0962-1849\(01\)80014-7](https://doi.org/10.1016/S0962-1849(01)80014-7)
- Burton, C. L., & Bonanno, G. A. (2015). Measuring ability to enhance and suppress emotional expression: The Flexible Regulation of Emotional Expression (FREE) Scale. *Psychological Assessment*, 28(8), 1-13. <https://doi.org/10.1037/pas0000231>
- Chen, S., Chen, T., & Bonanno, G. A. (2018). Expressive flexibility: Enhancement and

- suppression abilities differentially predict life satisfaction and psychopathology symptoms. *Personality and Individual Differences*, *126*, 78-84. <https://doi.org/10.1016/j.paid.2018>
- Faul, F., Erdfelder, E., Buchner, A., & Lang, A. G. (2009). Statistical power analyses using G*Power 3.1: Tests for correlation and regression analyses. *Behavior Research Methods*, *41*(4), 1149-1160. <https://doi.org/10.3758/BRM.41.4.1149>
- Finney, S. J., & DiStefano, C. (2006). Non-normal and categorical data in structural equation modeling. In G. R. Hancock and R. O. Mueller (Eds.), *Structural equation modeling: A second course*, (pp. 269-314). Greenwich, CT: Information Age Publishing.
- Fossion, P., Leys, C., Kempnaers, C., Braun, S., Verbanck, P., & Linkowski, P. (2014). Psychological and socio-demographic data contributing to the resilience of holocaust survivors. *The Journal of Psychology*, *148*(6), 641-657. <https://doi.org/10.1080/00223980.2013>
- Friborg, O., Barlaug, D., Martinussen, M., Rosenvinge, J. H., & Hjemdal, O. (2005). Resilience in relation to personality and intelligence. *International Journal of Methods in Psychiatric Research*, *14*(1), 29-42. <https://doi.org/10.1002/mpr.15>
- Griffin, K. W., Botvin, G. J., Scheier, L. M., Epstein, J. A., & Doyle, M. M. (2002). Personal competence skills, distress, and well-being as determinants of substance use in a predominantly minority urban adolescent sample. *Prevention Science*, *3*(1), 23-33. <https://doi.org/10.1023/A:1014667209130>
- Gross, J. J., & John, O. P. (2003). Individual differences in two emotion regulation processes: implications for affect, relationships, and well-being. *Journal of Personality and Social Psychology*, *85*(2), 348-362. <https://doi.org/10.1037/0022-3514.85.2.348>
- Maddi, S. R., Matthews, M. D., Kelly, D. R., Villarreal, B., & White, M. (2012). The role of hardiness and grit in predicting performance and retention of USMA cadets. *Military Psychology*, *24*(1), 19-28. <https://doi.org/10.1080/08995605.2012.639672>
- Ong, A. D., Zautra, A. J., & Reid, M. C. (2010). Psychological resilience predicts decreases in pain catastrophizing through positive emotions. *Psychology and Aging*, *25*(3), 516-523. <https://doi.org/10.1037/a0019384>
- Ozer, E. J., Best, S. R., Lipsey, T. L., & Weiss, D. S. (2003). Predictors of posttraumatic stress disorder and symptoms in adults: A meta-analysis. *Psychological Bulletin*, *129*(1), 52-73. <https://doi.org/10.1037/0033-2909.129.1.52>
- Rodin, R., Bonanno, G. A., Rahman, N., Kouri, N. A., Bryant, R. A., Marmar, C. R., & Brown, A. D. (2017). Expressive flexibility in combat veterans with posttraumatic stress disorder and depression. *Journal of Affective Disorders*, *207*, 236-241. <https://doi.org/10.1016/j.jad.2016>
- Sandvik, A. M., Hansen, A. L., Hystad, S. W., Johnsen, B. H., & Bartone, P. T. (2015). Psychopathy, anxiety, and resiliency—Psychological hardiness as a mediator of the psychopathy–anxiety relationship in a prison setting. *Personality and Individual Differences*, *72*, 30-34. <https://doi.org/10.1016/j.paid.2014.08.009>
- Silverman, A. M., Molton, I. R., Alschuler, K. N., Ehde, D. M., & Jensen, M. P. (2015). Resilience predicts functional outcomes in people aging with disability: A longitudinal investigation. *Archives of Physical Medicine and Rehabilitation*, *96*(7), 1262-1268. <https://doi.org/10.1016/j.apmr.2015.02.023>
- Southwick, S. M., Bonanno, G. A., Masten, A. S., Panter-Brick, C., & Yehuda, R. (2014). Resilience definitions, theory, and challenges: interdisciplinary perspectives. *European Journal of Psychotraumatology*, *5*(1), 1-14. <https://doi.org/10.3402/ejpt.v5.25338>
- Webb, T. L., Miles, E., & Sheeran, P. (2012). Dealing with feeling: A meta-analysis of the effectiveness of strategies derived from the process model of emotion regulation. *Psychological Bulletin*, *138*(4), 775-808. <https://doi.org/10.1037/a0027600>
- Westphal, M., Seivert, N. H., & Bonanno, G. A. (2010). Expressive flexibility. *Emotion*, *10*(1), 92-100. <https://doi.org/10.1037/a0018420>
- Yildirim, M. (2018). Mediating role of resilience in the relationships between fear of happiness and affect balance, satisfaction with life, and flourishing. *Europe's Journal of Psychology*, *15*(2), 183-198. <https://doi.org/10.5964/ejop.v15i2.1640>
- Yildirim, M., & Belen, H. (2019). The role of resilience in the relationships between externality of happiness and subjective well-being and flourishing: A structural equation model approach. *Journal of Positive School Psychology*, *3*(1), 62-76.
- Zhu, Z., & Bonanno, G. A. (2017). Affective flexibility: Relations to expressive flexibility, feedback, and

depression. *Clinical Psychological Science*, 5(6),
930-942.<https://doi.org/10.1177/2167702617717337>